

survitec

# MILITARY BOATS

PROVIDING CRITICAL SAFETY SOLUTIONS



# EXPERIENCE MATTERS

Survitec's DSB brand is synonymous with high quality boat engineering and advanced in-water performance. Leveraging over 8 decades of know-how in the design and manufacture of boats, Survitec has amassed a wealth of critical knowledge on materials construction, precision manufacturing, quality control and utilising user groups for testing and certification to engineer a collection of best-in-class solutions that gives users the upper-hand in any operational scenario.



[www.survitecgroup.com](http://www.survitecgroup.com)

▶ **INTELLIGENT  
DESIGNS**



- Performance enhancing patents
- Incredibly durable construction
- Optimised for maximum passenger/ equipment payload

▶ **QUALITY  
ASSURED**



- ISO and Module D certified
- Engineered to SOLAS Rescue Boat standards
- Tested at every stage of manufacture

▶ **UNRIVALLED  
KNOWLEDGE**



- User group experience and over 80 years expertise
- Combat proven across 4 continents
- In-house design and qualification skillset

▶ **CUSTOMER  
FOCUSSED**

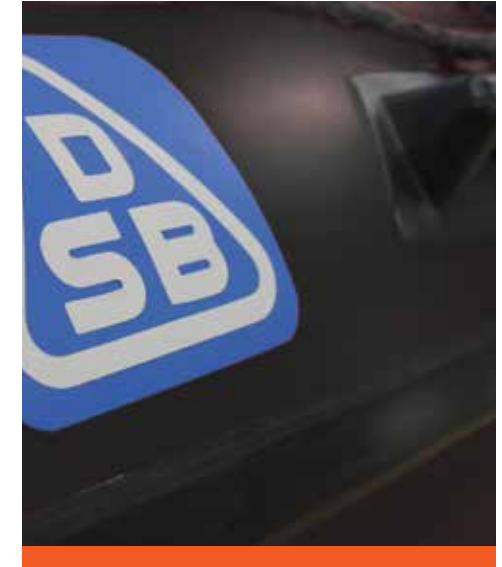

- Full customisation capabilities
- Modular and rapidly configurable solutions
- Complete through-life service
- Working Alongside the customer both on and off the water



## FULLY INFLATABLE BOATS

Manufactured from an ultra-light Hypalon fabric, the versatile DSB inflatable boat range employs weight saving design features to maximise the boats manoeuvrability and reduce the transportation and servicing burden. With a heavy duty reinforced construction and numerous innovative design features, the inflatable boat range is fully adaptable for a variety of applications including fast rescue, infiltration and extraction, and covert missions.

### ▶ Rapid Deploy Tow



Can be solely operated by the cox to extract stricken boats out of immediate danger

### ▶ Single Point Inflation



Twin or single bottle inflation, from one system. Allows for the operator to set up for mission specific insertion/extraction techniques.

### ▶ Capsize Line



Readily deployable and fixed to the buoyancy, to allow the operator to right the boat in all conditions

### ▶ Easy to pack and rapidly deployable



Deployable from helicopters, fixed wing aircraft and sub-surface assets.

### ▶ Low Maintenance Inflation Valves



Can be easily changed out with a socket set, to save on cutting out/replace damaged valves

### ▶ Cargo Net



Detachable cargo net mounted into a sleeve on the bow of the boat. Elasticated for ease and added security of equipment

## Inflatable Boats

### Configurations and Technical information

	2 Man	380 GP	420 GP	470 GP	530 GP	600 GP	380 GPM	420 GPM	470 GPM	530 GPM	580 GPM
Length overall (m)	2,300	3,800	4,200	4,700	5,300	6,000	3,800	4,200	4,700	5,300	5,800
Width overall (m)	1,100	1,670	1,800	1,980	2,135	2,600	1,670	1,800	1,955	2,135	2,500
Length inside (m)	1,720	2,595	2,960	3,420	3,795	4,830	2,595	2,960	3,400	3,795	4,540
Width inside (m)	0,500	0,760	0,890	0,980	1,035	1,400	0,760	0,890	0,915	1,035	1,160
Weight hull (kg)	13	44	50	68	82	107	51	57	81	95	122
Weight wood floor (kg)	-	40	52	63	82	120	41	53	64	83	99
Weight roll-up floor (kg)	-	35	46	54	73	n.V.	36	47	55	74	89
Weight aluminium floor (kg)	-	38	50	58	71	103	39	51	59	72	88
Weight inflatable floor (kg)	-	-	-	-	-	-	9	10,9	12,5	14,5	-
Buoyancy chambers (Stk)	2	3	5	5	5	6	3	5	5	5	5
Max. Payload (kg)	155	830	930	1250	1720	2420	830	930	1420	1720	2530
Crew limit (Stk)	2	6	7	10	12	21	6	7	10	12	16
Max. Motorization (KW) / (PS)	2    2,7	29,4    40	37    50	44    60	51,5    70	58,8    80	29,4    40	37    50	44    60	51,5    70	73,5    100
Max. Weight motorization (single or twin) (kg)	20	115	125	125	135	185	115	130	140	140	185
Buoyancy (m3)	0,33	1,22	1,37	1,83	2,55	3,41	1,22	1,37	1,98	2,42	3,52
Boat inner surface (m2)	0,76	1,82	2,42	2,93	3,58	6,45	1,82	2,42	2,93	3,58	4,96
Dimensions stowed boat lxbxh (cm)	78x50x20	115x58x30	130x60x35	145x70x40	155x75x42	175x80x40	115x58x30	130x60x35	145x70x40	155x75x42	175x80x40
Dimensions stowed standard equipment lxbxh (cm)	-	110x63x20	115x70x20	125x68x22	140x68x22	163x130x22	110x63x20	115x70x20	125x68x22	140x68x22	140x87x22
Tube diameter (cm)	30,00	45,5	45,5	50,0	55,0	60,0	45,5	45,5	52,0	55,0	63,0
Tube diameter bug (cm)	-	42,0	42,0	45,0	53,0	50,0	42,0	42,0	47,0	53,0	53,0
Fabric	Hypalon 1100 dtex	Hypalon 1100 dtex	Hypalon 1100 dtex	Hypalon 1100 dtex	Hypalon 1100 dtex	Hypalon 1100 dtex	Hypalon 1670 dtex	Hypalon 1670 dtex	Hypalon 1670 dtex	Hypalon 1670 dtex	Hypalon 1670 dtex

## Inflatable GPM Boat Specification

### STV Valve

Switchable transfer valves, for use with rapid inflation and deflation for subsurface caching

### Single Point Inflation

Single/Twin depending on task. Can inflate 5.3 M boat in 1 minute

### Single/Twin Soft Handles

Rounded for better grip and push flat to the buoyancy to avoid snagging hazard

### Keel

Reinforced underside to prevent wear from sand/stone collected and fitted into a sleeve to change out without tools

### Military EV55 Inflation Valve

Flush to the buoyancy and interchangeable with a simple socket tool, no need to cut out and replace damaged valves, unique to Survitec

### Grip Patches

To assist personnel with raiding, boarding and secure seating of pax

### Multiple floor options

As per customer requirements

### Military EV55 Inflation Valves

Positioned to minimise residual air during recovery of sub-surface assets

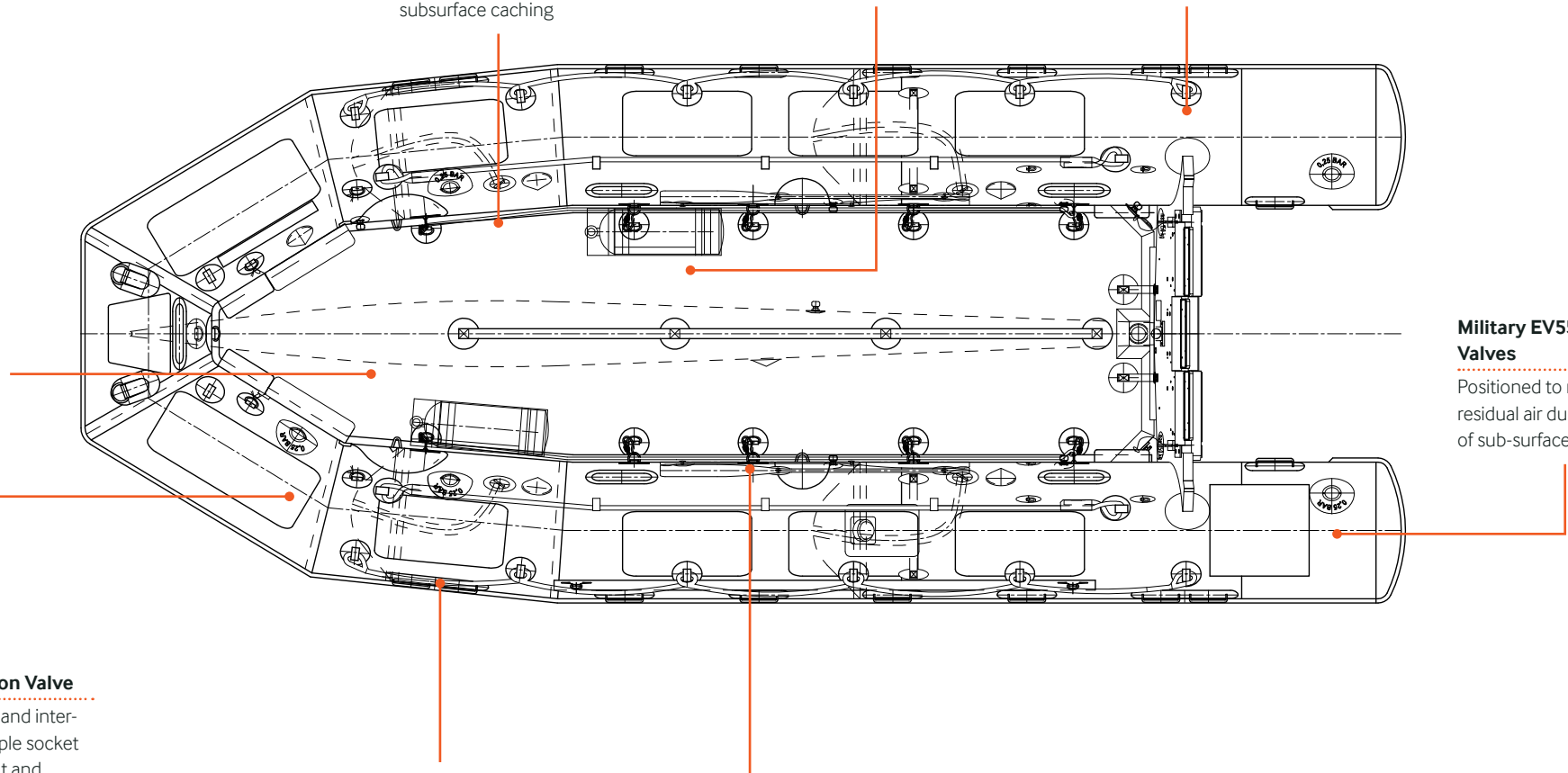

## Inflatable GPM Boat Specification

### Front tow sustainment handle

Constructed from stainless steel, ensures safe handling

### Towing Points

2 x towing points, also used in conjunction with the 3 leg strop, designed to assist in sub-surface caching

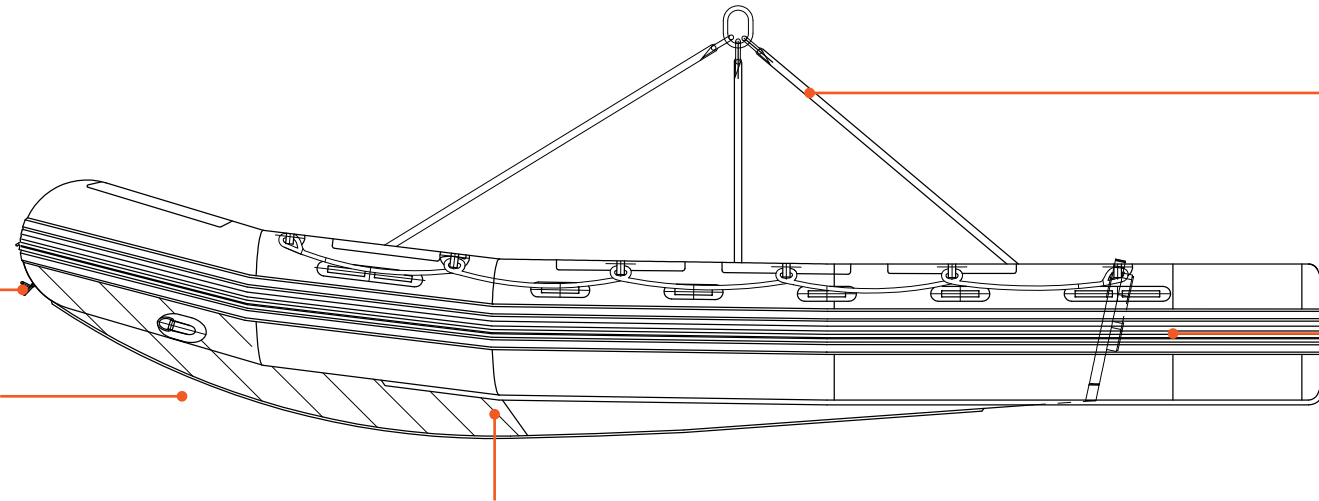

### Lifting Strop

Up to six legs for heavier loads and larger craft (530, 580)

### Rubbing Strake

Offers an additional layer of protection, for maximum through-life performance. Built in lip to reduce sea spray

### Double Hull

Full or partial for protection against landings and groundings

### Rubbing Strake

Continued around the aft of the buoyancy tube

### Towing Bracket, Transom

Constructed from laser cut steel, ensures safe towing

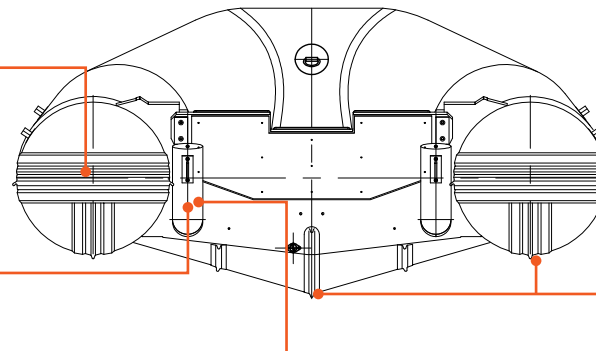

### Keel/Buoyancy reinforcement

Added keel/fender reinforcement giving additional protection during beaching and improving manoeuvrability.

### Self-Sealing Bailers

Designed not to allow water back into the boat even when deployed



## Inflatable boats standard specification

### GPM

Buoyancy/Hull made up of 1670 DTEX	Edge protection along top of transom and keel line
2x Self-sealing drain outlets (100mm)	Cutting area in each buoyancy compartment for emergency repair
Drain bung	'D' ring bow centre for painter line
Engine clamp plate, universal or tailored to engine	Pressure relief valve in all buoyancy chambers
2x towing eye on transom	'D' ring lashing points
2x Outer and 2x inner braided life lines, 2x inner 3 ply kit line	Lifting eyes
Tow/carry handle at bow	Capsize line built in to buoyancy
2x Towing 'D' ring at bow	Reinforced underside of inflatable keel
Carrying handles various depending on size	Anti-slip patches on buoyancy
EV55 inflation valves	Switchable transfer valves (STV)
Rubbing strake	<b>Ancillaries:</b>
'V' shape rubbing strake along keel and buoyancy	1x foot bellows
Paddles	1x repair kit
3x pockets for berthing lines	2x 6 meter, 10 mm octoplatit berthing lines
Stowage bag for hull	1x tow rope set
	1x emergency bladder



### Optional Extras

- Single-point inflation / underwater cache kit including: Switchable transfer valves
- Hard, roll up or inflatable floor
- Deck line, inflatable floor only
- Inflatable helmsman seat
- Fixation patches for paddles/fuel lines
- Fast deploy tow
- Navigation board
- Cargo net in a pouch
- Additional rubbing strake/Armour
- Mounting tool for replacing the filling valve EV55
- Customized engine clamp plate
- Pressure gauge
- Sea anchor
- Boat anchor
- Roaming Inflator Hose
- Lifting sling set (4 legged/6 legged)
- Three-legged strop for pulling boat sub-surface
- Tarpaulin (boat cover)
- Fairlead (for EOD operations)
- Environmental boat cover

## Inflatable boats standard specification

### GP

---

Buoyancy/Hull made up of 1100 DTEX

---

2x Self-sealing drain outlets

---

Drain bung

---

Engine clamp plate, universal or tailored to engine

---

2x towing eye on transom

---

2x Outer braided life lines

---

Tow/carry handle at bow

---

2x Towing 'D' ring at bow

---

Carrying handles various depending on size

---

Standard inflation valves

---

Rubbing strake

---

'V' shape rubbing strake along keel

---

Paddles

---

3x pockets for berthing lines

---

Stowage bag for hull

---

#### Ancillaries:

1x foot bellows

1x repair kit

2x 6 meter, 10 mm octoplat berthing lines

---



### Optional Extras

- Single-point inflation / underwater cache kit including: Switchable transfer valves
- Hard, roll up or inflatable floor
- Deck line, inflatable floor only
- Inflatable helmsman seat
- Fixation patches for paddles/fuel lines
- Fast deploy tow
- Navigation board
- Cargo net in a pouch
- Additional rubbing strake/Armour
- Mounting tool for replacing the filling valve EV55

- Customized engine clamp plate
- Pressure gauge
- Sea anchor
- Boat anchor
- Roaming Inflator Hose
- Lifting sling set (4 legged/6 legged)
- Three-legged strop for pulling boat sub-surface
- Tarpaulin (boat cover)
- Fairlead (for EOD operations)
- Environmental boat cover



## SEMI-RIGID BOATS

The heavy duty, robust semi-rigid boats incorporate maximum durability, increased manoeuvrability and excellent through-life performance. Featuring a durable sea-water-resistant aluminium sandwich hull of frame and stringer construction and an environmentally resilient Hypalon buoyancy tube, each boat possesses a fully modular design capable of incorporating multiple customisable attributions such as helmsman/crew console, navigation systems, seats, stowage and weapons configurations.

### ► Highly quality construction



Extremely durable heavy duty hull with coated Hypalon fender.

### ► Excellent in-water performance



Optimal weight to power ratio enables faster acceleration and superior handling.

### ► Intelligent, practical design



Enhanced support/splash guards at vital components, cone chamber separator technology to counteract punctures.

### ► Modular design, fully customisable



Facilitates multiple operating requirements – weapons, med evac, recon, SAR.

### ► Fully integrated electronics



GPS, lighting, night vision, thermal imaging, radar, speedometers, echo sounders.



**Robust aluminium hull structure of frame and stinger construction**

Concealed safety buoyancy chamber ensures full float/payload capability even when fender is uninflated

**Helmmann console**

Full customisation options available as per requirements

**Flush hull integrated lifting brackets**

**Front belaying cleats and brackets module, front towing eyelet**

Two different installation points

**Front re-enforcement modules**

Constructed of durable rubber or aluminium

**Multiple A- frames**

With bespoke outfitting capabilities (navy lights, electronics)

**Self-bailing deck**

Ensures no water retention on boat

**Anti-skid pads**

For proper gripping when standing on boat

**Ergonomic seat**

Systems and configuration options available as per customer requirements

**Multiple rope**

Arrangements in loops or straight with sliding handle systems

**Deck integrated installation points**

Facilitates multiple configurations including weapons, medical evacuation.

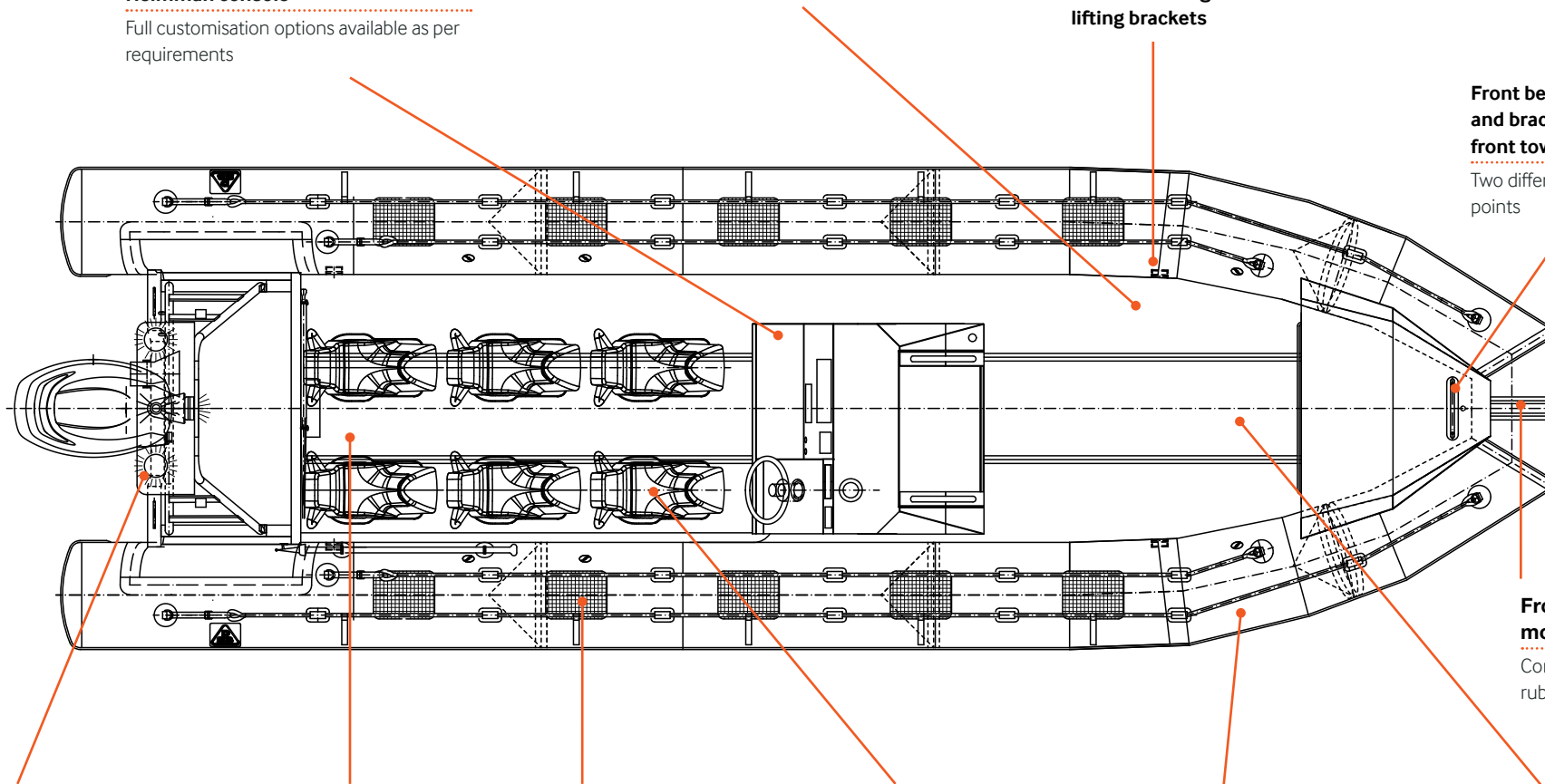

**Single or twin outboard configuration and inboard engines**

Options available as per customer requirements

**Hull inspection access at transom**

Transom with belaying cleat and extra towing eyelets, set of two different brackets ensures free access to lifting, towing or belaying/mooring

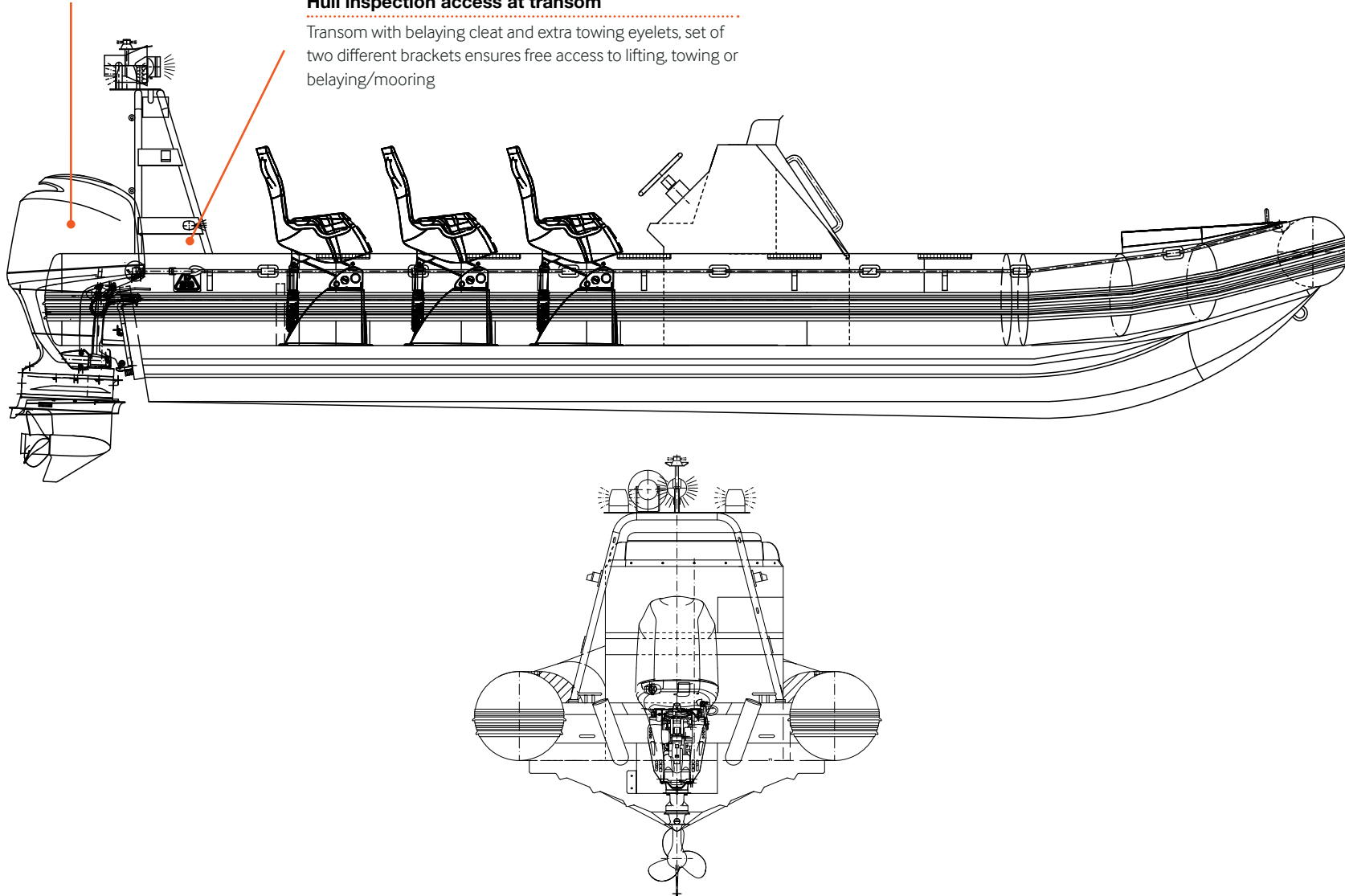

## USER DEFINED DESIGNS

Customise each element of your boat to ensure a tailored fit to your operational needs

▶ Transom



▶ Helmsman console



▶ Engines



▶ Electronics



▶ Seats



▶ Stowage



▶ Anchor



▶ Floor





## Customisation

Feature	Options
<b>Transom Outfit</b>	<ul style="list-style-type: none"><li>• Light Stick</li><li>• A-Frame Single</li><li>• A-Frame</li></ul>
<b>Helmsman Console</b>	<ul style="list-style-type: none"><li>• Front</li><li>• Centre</li><li>• Rear</li></ul>
<b>Engines</b>	<ul style="list-style-type: none"><li>• Make</li><li>• Model</li><li>• Output Capacity</li></ul>
<b>Electronics</b>	<ul style="list-style-type: none"><li>• Navigation</li><li>• Echo Sounders</li><li>• Lighting</li><li>• Speedometers</li><li>• Night Vision</li><li>• Thermal Imaging</li><li>• Radar Over</li></ul>
<b>Seats</b>	<ul style="list-style-type: none"><li>• Quality</li><li>• Standard</li><li>• Attenuating</li></ul>
<b>Stowage</b>	<ul style="list-style-type: none"><li>• Type</li><li>• Location</li><li>• Size</li></ul>
<b>Anchor</b>	<ul style="list-style-type: none"><li>• Type</li><li>• Material</li></ul>
<b>Floor</b>	<ul style="list-style-type: none"><li>• Inflatable</li><li>• Roll Up</li><li>• Segmented</li></ul>



## EQUIP YOUR BOAT'S CREW

### One source for all your safety survival needs

Survitec Group offers the complete package in maritime survival operations. Equip your crew in full head to toe maritime survival equipment from Survitec including coveralls and survival suits, lifejackets and armour capable vests with soft/hard armour and flotation capabilities.

Survival suits

Life preservers

Medical equipment

Covert liferafts

Load carriage protection

For the complete range visit

[www.survitecgroup.com](http://www.survitecgroup.com)







## GET IN TOUCH

### **SURVITEC**

1-5 Beaufort Road, Birkenhead, CH41 1HQ, United Kingdom

**Email:** [info@survitecgroup.com](mailto:info@survitecgroup.com)

**[www.survitecgroup.com](http://www.survitecgroup.com)**

### **Copyright Notice**

The copyright, trademarks, domain names and other intellectual property rights in all material and information in this presentation belongs to Survitec Group Limited. All rights are reserved.

### **Disclaimer**

This document provides general information about Survitec Group and its companies, its products and services, and summarises general capabilities and offerings which we deem to be of relevance to our customers. Whilst Survitec has taken appropriate steps to ensure the accuracy of the information contained in this document, Survitec gives no warranty regarding the accuracy or completeness of such information.

This presentation was prepared to provide information and does not constitute a contract. Survitec reserves the right, without prior notice, to change, delete, supplement, or otherwise amend at any time the information, images, and offerings contained in this presentation, or other documents. Survitec shall not be liable for any loss or damage of whatever nature (whether direct, indirect, consequential or other) that may arise as a result of any third party relying on the information contained in this document (but nothing in this disclaimer excludes liability for death or personal injury arising from negligence or any fraudulent misrepresentation).

For further detailed information, prices, terms and conditions, customers should contact Survitec at [info@survitecgroup.com](mailto:info@survitecgroup.com)